



Inline Vision System

Videojet 5230

Simple user interface and proven reliability of the Videojet 5230 Print Presence System helps enable accurate detection of printed text and codes.

Ensure printed code presence.

Seamless integration in a production line.

Improve quality and optimize production efficiency.



- Take a photo of the text
- Process the image and calculate the amount of marking on the product.
- Compare the amount of marking with a threshold reference

Consumer Confidence

- Increase the quality of the product by assuring that the needed information is fully printed (Best Before Date, LOT, etc.)
- 100% quality-inspected products placed into the market
- Maintain brand quality by ensuring code presence on all products

Setup made easy

- Setup time is minimized by integral SKU/article management
- Threshold setup is simplified with a very user friendly operator interface

Communication & Connectivity

- Remove potential for human error with suite of line integration and code management capabilities
- Management of marking system codes directly from the Vision controller
- Multiple cameras/printers can be connected together and be setup from a central point

Production Efficiency

- Reduce costs caused by rework, recalls and scrap
- Fast and reliable set-up and change-over ensures high OEE
- End-of-Batch report gives Production Managers the best traceability for quality issues

Videojet 5230

Inline Vision System

User interface and software

Laetus NAVIGATOR for MS Windows®

Languages

English

Further languages at request

Inspection System

Inspector wt621 smart camera system, 1280x 1024 Pixel, monochrome, max. 50 fps, embedded operating system, 1 Trigger input, 3 input signals for future use, 4 result outputs, integrated LED lighting red/blue, LED class 1, strobe control of external lighting, integrated 9.6 mm lens with software adjustable focus, reading distance 70 ... 1.500 mm, optical indicators (5x status display, 10x LED bar, 1 green feedback), beeper/buzzer, connectivity prepared for Profinet, EtherNet, EtherCAT, PROFIBUS DP

Print Presence Application

Contrast based pixel counter, standard or inverse printed style, adjustable acceptance level versus trained reference print, configurable print analysis, application window tracker tool.

Inspection Line speed capability

Depends on application, typically up to 25 Hz

Working Distance / Field of View

Note: 17.1 mm lens not available

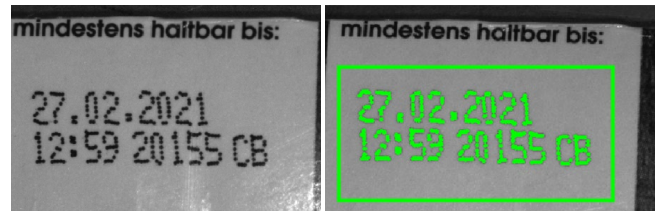
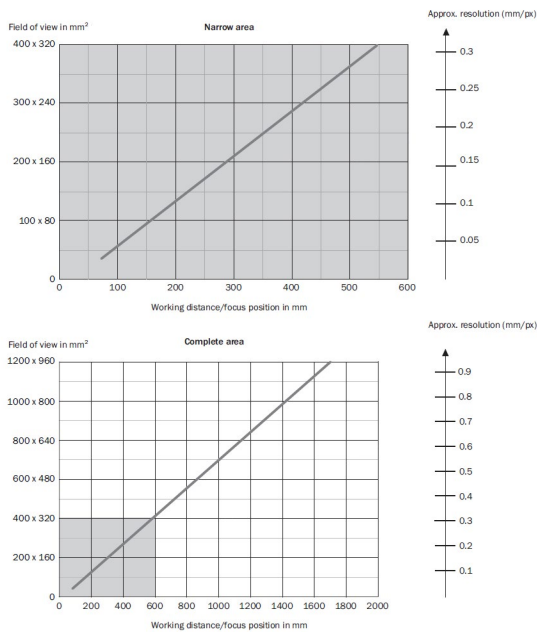

Environmental protection

Inspection camera IP65

Option- stainless steel cabinet IP54 (fan less)

Temperature/humidity range

0°C to 50°C (32°F to 122°F)

0% to 90% RH non-condensing

Electrical requirements

100-240 VAC at 50/60 Hz, approx.. 60W, 24V / DV 240W power supply included

8-port Ethernet Switch included

Package Options

COMMANDER 110S, 10" Touch Panel, Windows 10 IoT Enterprise operating system, 128GB SSD

Electrical cabinet, stainless steel, incl. 24V DC power supply, 8-port Ethernet switch, terminal blocks for 2 inspection cameras, Fault stop signal and indicator

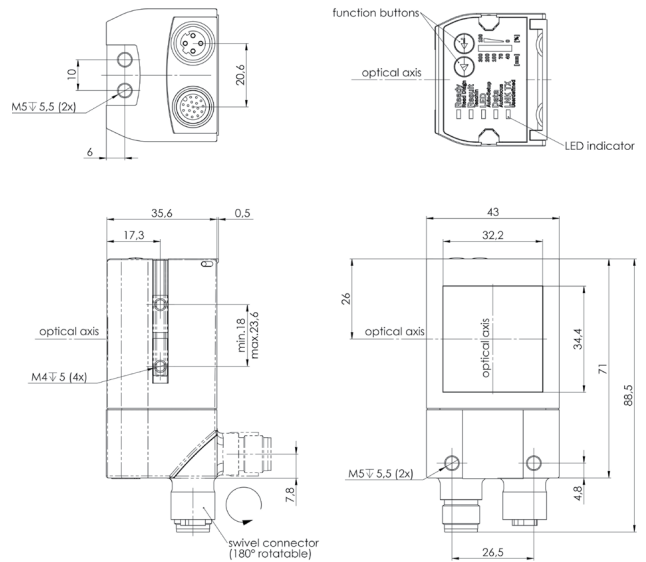

Inspector wt621

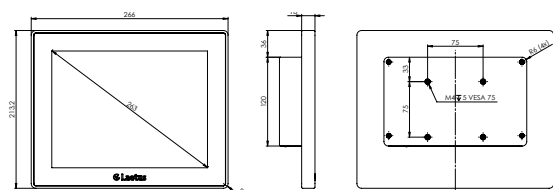

COMMANDER 110S

Call **+41 (0)62 388 33 33**
 Email **info.switzerland@videojet.com**
 or visit **www.videojet.ch**

Videojet Technologies Suisse GmbH
 Gummertliweg 7
 4702 Oensingen

© 2021 Videojet Technologies Inc. — All rights reserved.

Videojet Technologies Inc.'s policy is one of continued product improvement. We reserve the right to alter design and/or specifications without notice.

Part No. SL000696
 ss-5230-print-presence-en-ch-0721

